

# **REINHOLD ENVIRONMENTAL Ltd.**



## **2011 NO<sub>x</sub>-Combustion Round Table & Expo Presentation**

February 7-8, 2011, in Birmingham, AL / Hosted by Southern Company

All presentations posted on this website are copyrighted by Reinhold Environmental, Ltd (RE). Any unauthorized downloading, attempts to modify or to incorporate into other presentations, link to other websites, or obtain copies for any other uses than the training of attendees to RE's Conferences is expressly prohibited, unless approved in writing by RE or the original presenter. RE does not assume any liability for the accuracy or contents of any materials contained in this library which were presented and/or created by persons who were not employees of RE.



# ***Dynamic SO<sub>3</sub> Measurement and Injection Control***

---

Methods for BACT Compliance



## Discussion Outline

- *Measurement Technology*
- *Acid Distribution Considerations*
- *Adaptive Injection System Design*
- *Questions*



# ***Measurement Background***

---

A Probe Primer



# AbSensor – AbS/SO<sub>3</sub>

## What is it? What does it do?

- ⦿ In-Situ, Continuous measurement
- ⦿ Temp at which material condenses out from flue gas

This material could be:

- ⦿ Moisture (H<sub>2</sub>O),
- ⦿ Sulfuric Acid (H<sub>2</sub>SO<sub>4</sub>) (H<sub>2</sub>O + SO<sub>3</sub>)
- ⦿ Ammonium Bisulfate (NH<sub>3</sub>HSO<sub>4</sub>) (NH<sub>3</sub> + H<sub>2</sub>O + SO<sub>3</sub>)
- ⦿ Sodium Bisulfate

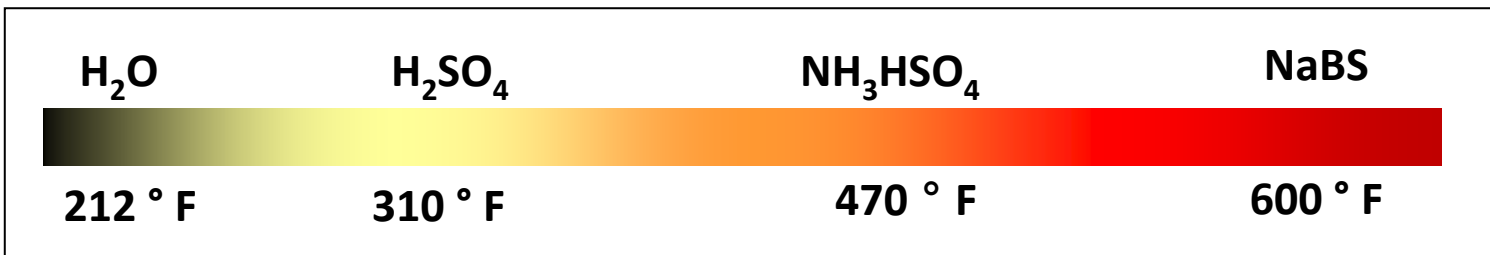

The same device measures condensables across the spectrum!



# AbSensor - Introduction

Condensation = Evaporation

Equ

Tip Temp

The Condensables System Output is:

**Formation Temp:** The temperature at which material will first form

**The Equilibrium Dewpoint**

**Evaporation Temp:** The temperature at which material will self-evaporate

Tip Current

A hot probe is precisely cooled until condensation current is detected. (Formation Point).

Condensation > Evaporation

The probe is allowed to heat in the Flue Gas until the current goes below a threshold (Evaporation Point).

Evaporation > Condensation

Cooling Air Return

Cooling Air Inlet

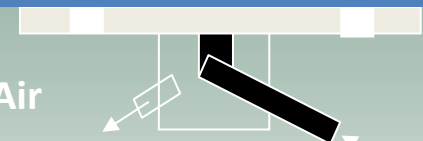



# Condensable States

Condensable States are derived in rising order of fouling severity:

- 0: No Condensable Detected**
- 1: H<sub>2</sub>O + SO<sub>3</sub>**
- 2: SO<sub>3</sub>**
- 3: SO<sub>3</sub> + Ammonium Sulfate**
- 4: SO<sub>3</sub> + Ammonium Bisulfate**
- 5: Low ABS**
- 6: Medium ABS**
- 7: High ABS**
- 8: Sodium Bisulfate**



## Condensable States

- The “Condensable States” are Breen-derived terms that relate to relative severity of the fouling potential in an air heater environment.
- Clearly an academic argument could be made as to what material constitutes Low ABS vs. high levels of sulfuric acid.
- In all cases the data is subjected to a sanity test and quantitative values are derived from qualitative findings



# **FLUE GAS CONDENSABLE REPORTS**



# Sample Reports



*Case #2*

# **POST AIR HEATER STRATIFICATION**



# Stratification

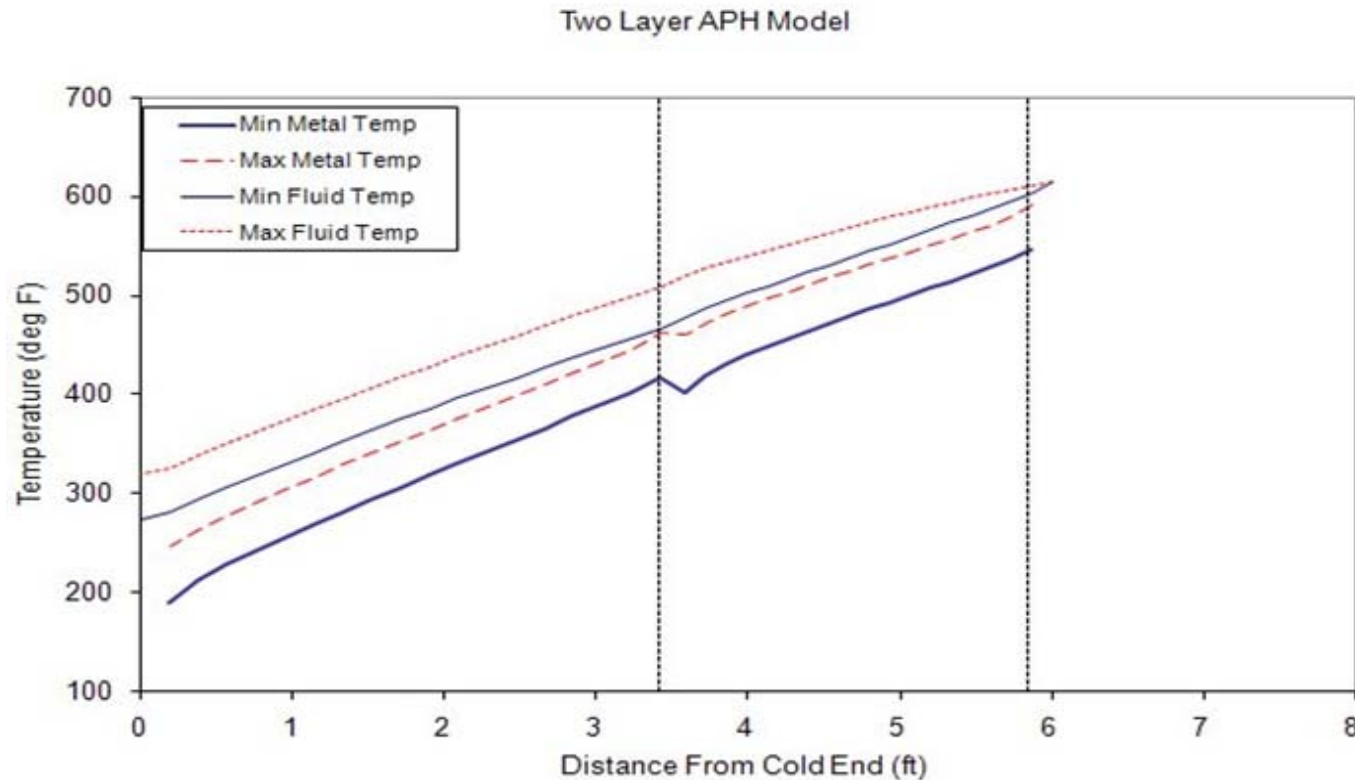

Courtesy of EPRI-APFG Predictive Software Algorithm



# Stratification

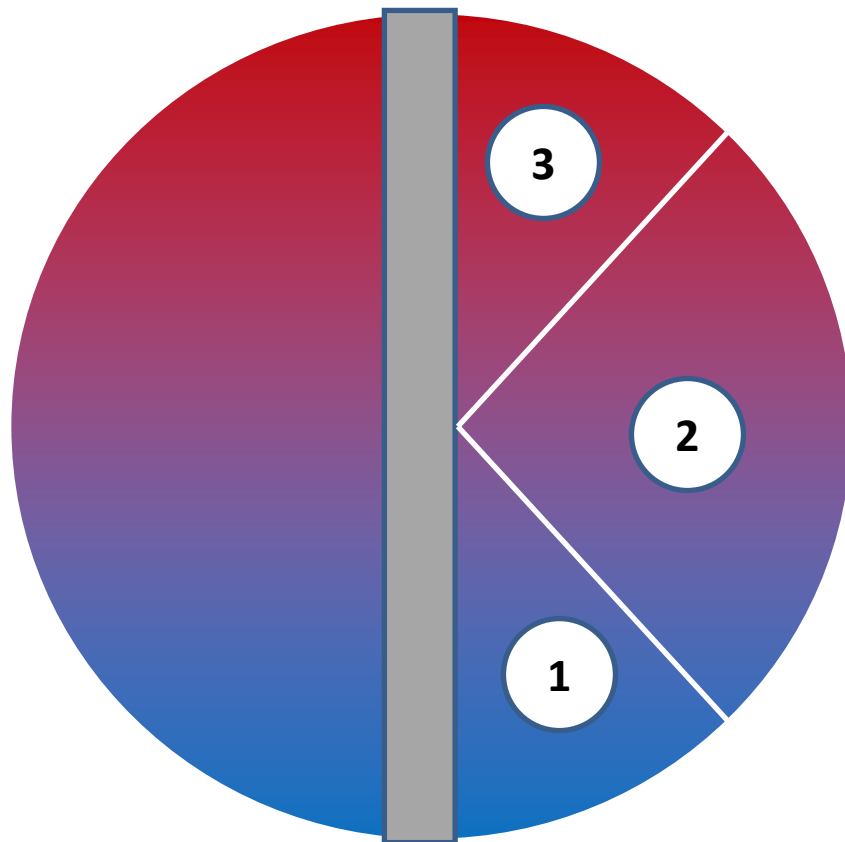

**1: Acid Vapor preferentially condenses on the AH plates creating an acid lean flue gas**

**2: AH plates warm to a point where acid vapor no longer condenses leaving an acid neutral flue gas**

**3: AH plates heat up to a point where condensed acid is re-vaporized creating an acid rich flue gas**



# Stratification

Hot Gas

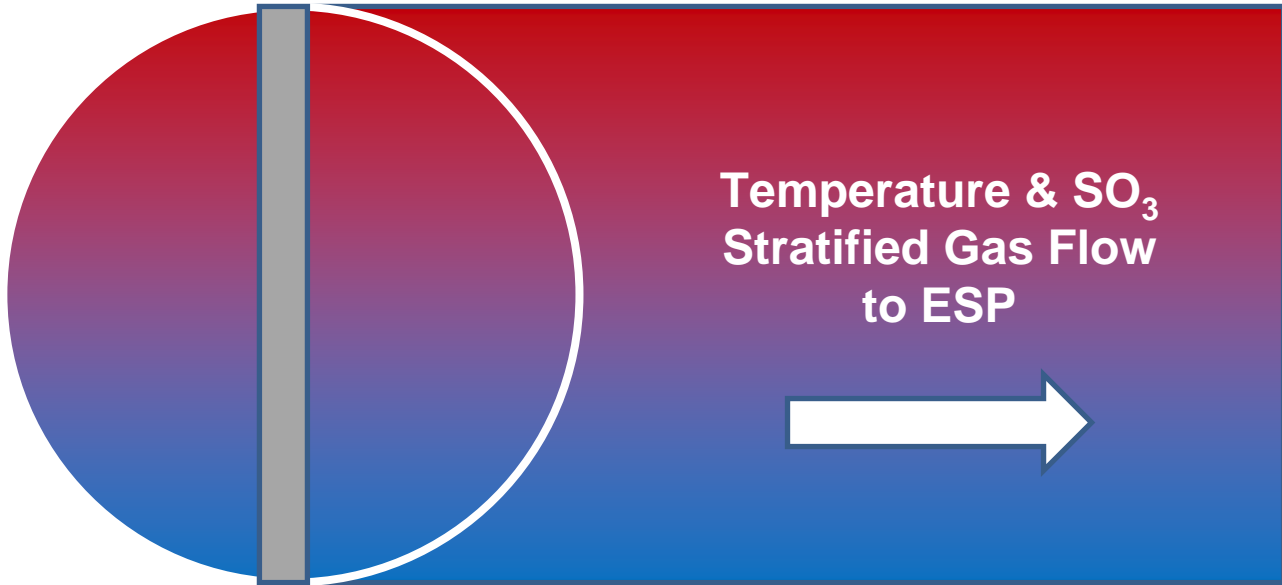

High Temp  
High SO<sub>3</sub>

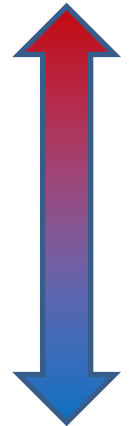

Low Temp  
Low SO<sub>3</sub>

Cold Air





# Stratification

High Temp  
High SO<sub>3</sub>

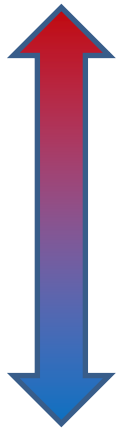

Low Temp  
Low SO<sub>3</sub>

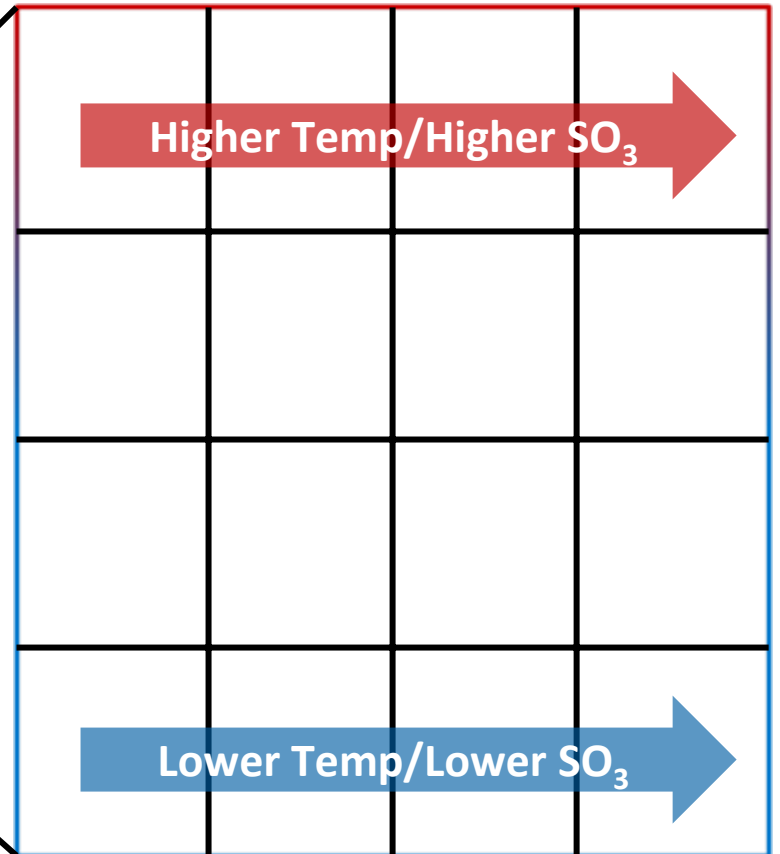
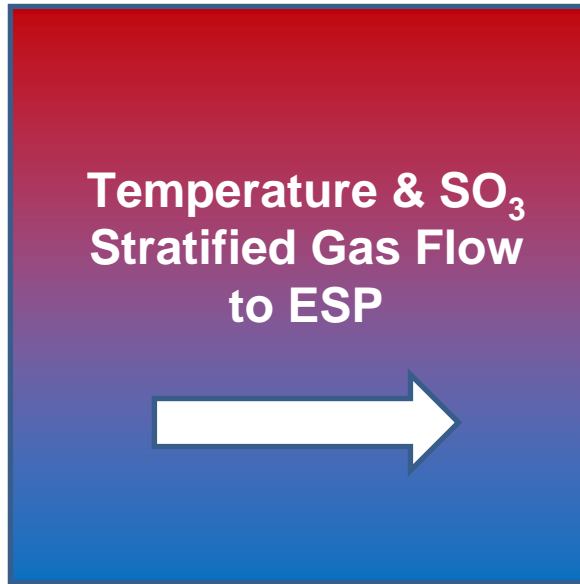



# The Porridge Effect

## ESP Considerations:

ESP Outlet opacity in the presence of increased acid mist is a combination of physical particulate and condensed acid vapor.

1. Over treatment of the acid will create under conditioned, high resistivity ash leading to higher particulate emissions
2. Under treatment of the acid will create over conditioned, low resistivity ash leading to higher particulate emissions with added acid mist
3. Proper treatment of the acid will create proper levels of residual SO<sub>3</sub> for ash resistivity correction while removing additional acid mist loading



# What Happens when the Acid Moves?

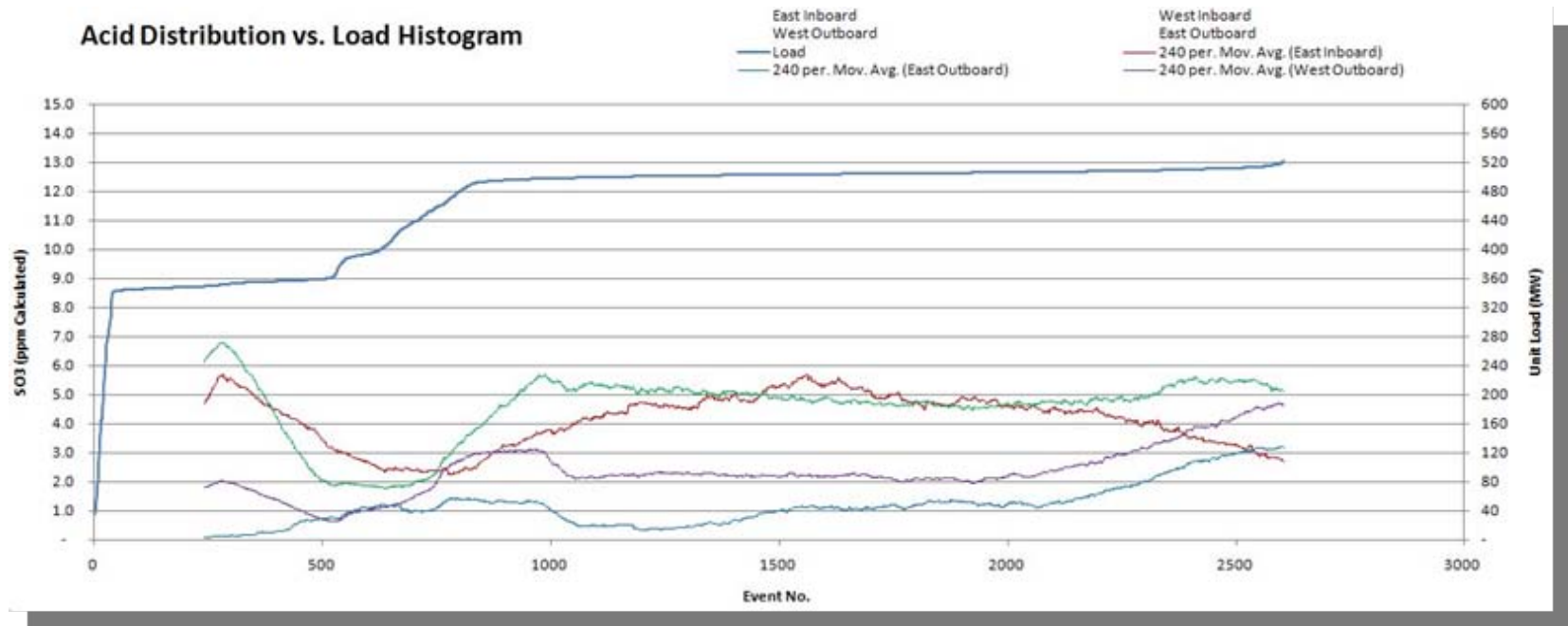

Changes in acid distribution result in changes in localized NSR  
This makes it extremely hard to meet opacity limits over varying loads



# ***Dynamic Injection Technology***

---

Matching the Sorbent to the Acid



# Breen Sorbent Injection Biasing

## The Problem to be Addressed:

- Dry Sorbent Injection systems currently strive for even distribution of reagent in the duct
- However, SO<sub>3</sub> and other condensables after the air heater are highly stratified
- Moreover, the location of the stratified material moves with load and flue gas temperature changes
- For proper matching of reagent to acid, Sorbent distribution should dynamically adjust to acid concentration



# Breen Sorbent Injection Biasing

## Current Industry Practice



- Material leaves the rotary gate and splits into two trunk lines
- Each trunk line feeds a 1:4 splitter (shown at left), generally known as a spider



# Breen Sorbent Injection Biasing



- Material then leaves the 1:4 splitter and is split again before entering the injection nozzle
- Before entering the injector, the material flow is observed, often through some type of visible sight glass



# Breen Sorbent Injection Biasing

- While this approach has been employed for years by many system users it is:
  - 1) Non-optimized
  - 2) Can lead to Bisulfate formation and deposition
  - 3) Maintenance intensive
- So how can the system be modified to optimized performance and minimize maintenance?



# Breen Sorbent Injection Biasing

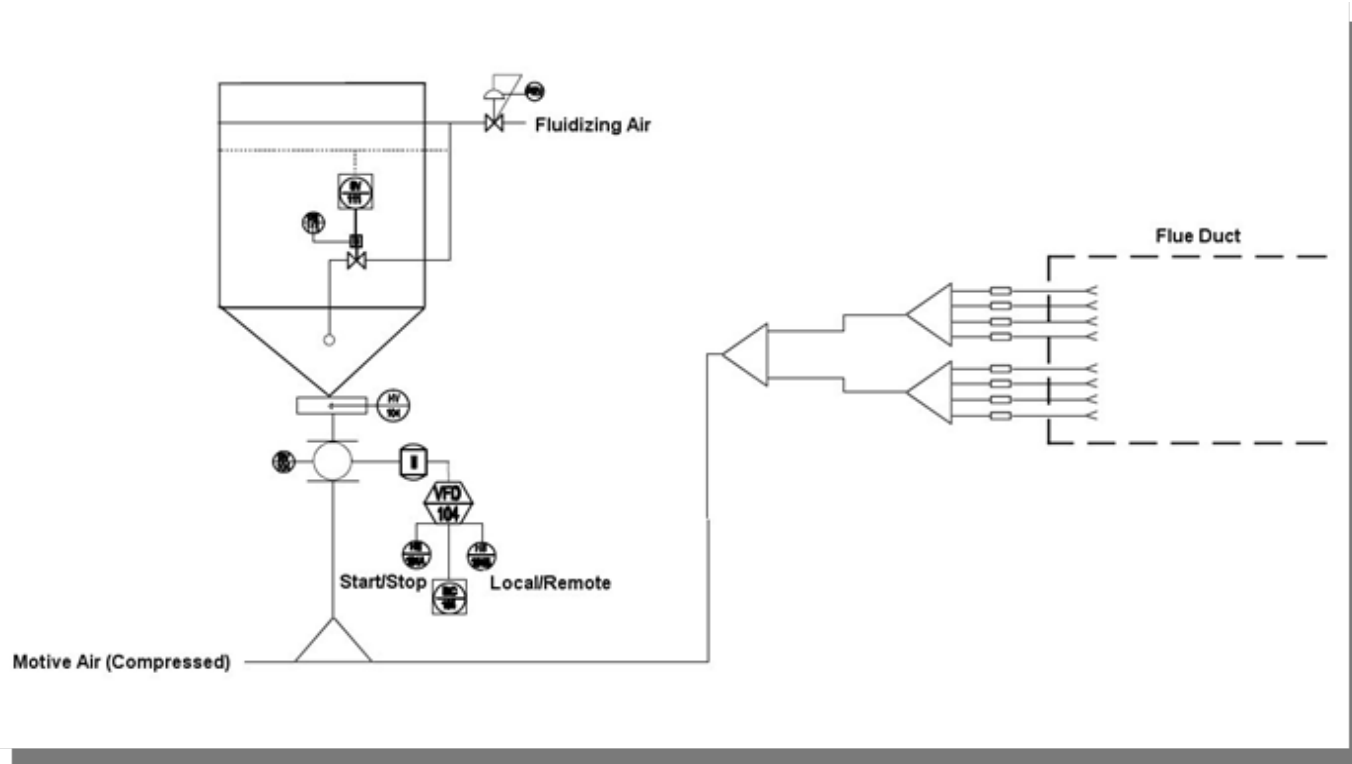

A typical dry sorbent injection system with 8 injection lance configuration



## Case Study #3 – Breen Sorbent Injection Biasing

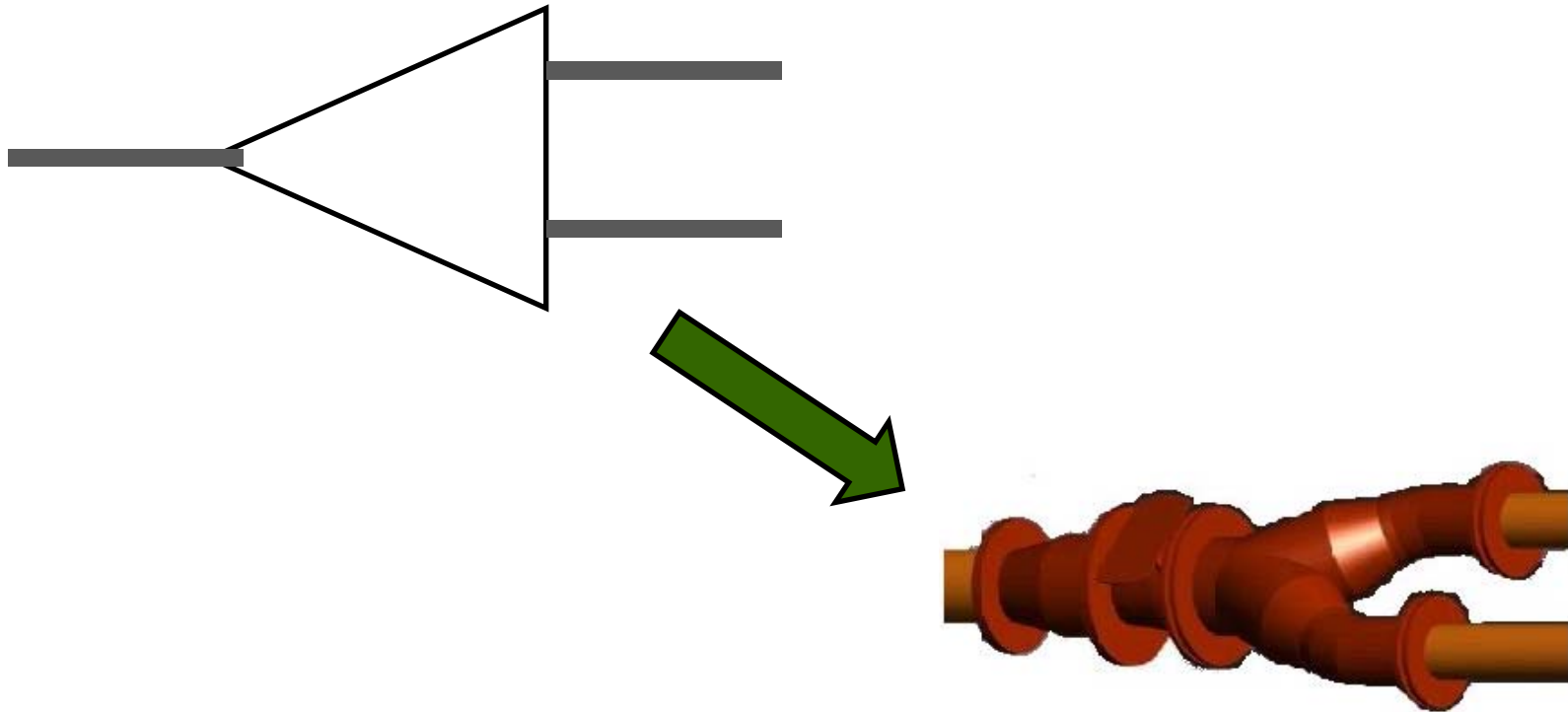

**Step 1- Replace the industry standard splitter  
with a VARB/Control Gate System**



Technology Sidebar

# **WHAT IS VARB TECHNOLOGY?**



# VARB Technology Hardware Base – a Customized Diffuser

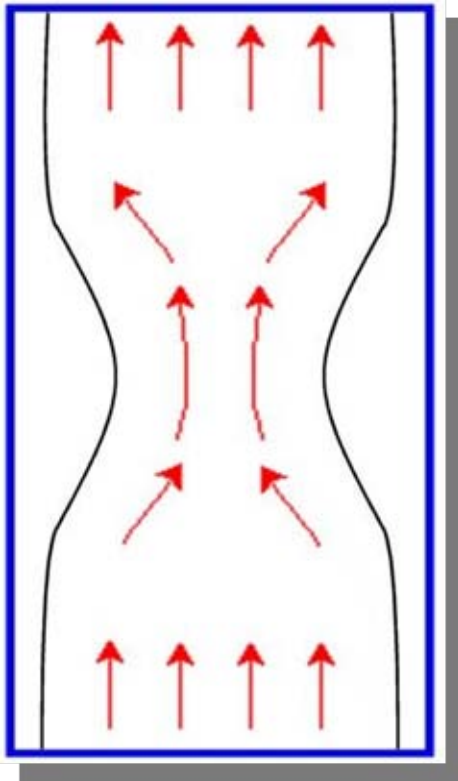

- 1) VARB action consists of repositioning the rope with a calculated drop in x-axis dimension and a corresponding increase in y-axis velocity.
- 2) This action is then followed by a specifically designed increase in x-axis dimension with a corresponding drop in y-axis velocity.
- 3) The result is an engineered disruption of the rope binding force allowing the coal particles to naturally distribute themselves within the air flow.



# VARB Technology Hardware Base – a Customized Diffuser

1) Each VARB is customized to the specific plant application.

2) The severity of the convergence and the subsequent divergence is considered based on the CFD results

3) The final VARB design selected will be an extension of one of the basic VARB families:

S - VARB

A - VARB

H- VARB





# **VARB Technology Hardware Base – a Customized Diffuser**

While venturi-based techniques are not new, or unique, to Greenbank, patents are in process on:

- Determination of convergent and divergent dimensions based on site specific modeling,
- Unique internal components to locate the process for improved efficiency,
- Incorporation of a biasing “control” gate for dynamic adjustment



# VARB Technology Control – Manual or Automatic Response

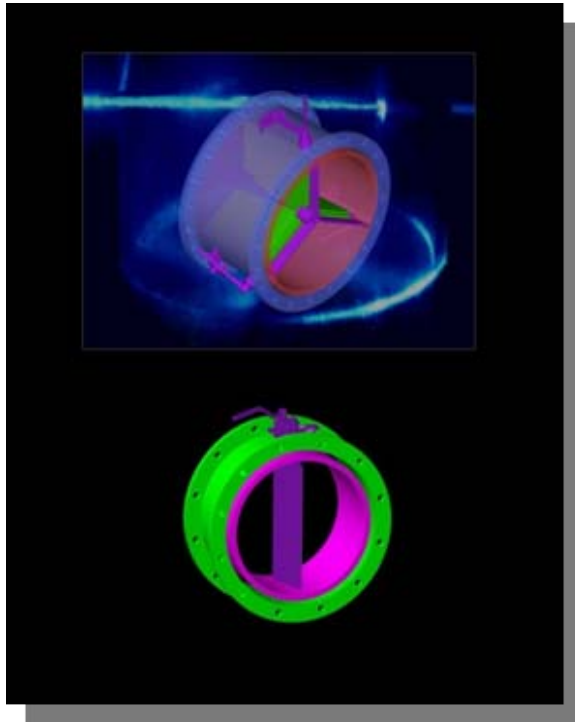

- Once the rope is broken and the coal distribution is returned to its homogenized condition, the coal/air fluid passes through the VARB Control Gate.
- This gate can be supplied in Bi, Tri, or Quad configuration and allows biasing of the homogenized fluid based on natural differences in piping pressure or desires for biased coal flow.
- The VARB control gate can be manually adjusted, configured for two state operation (load following) or configured for dynamic response to on-line coal flow measurement systems.



# VARB Technology Improved Control with Reduced Back Pressure

Due to its reduced surface area, the VARB presents a lower system Delta P

Riffler vs. VARB DP Comparison - Low Fuel to Air Ratio

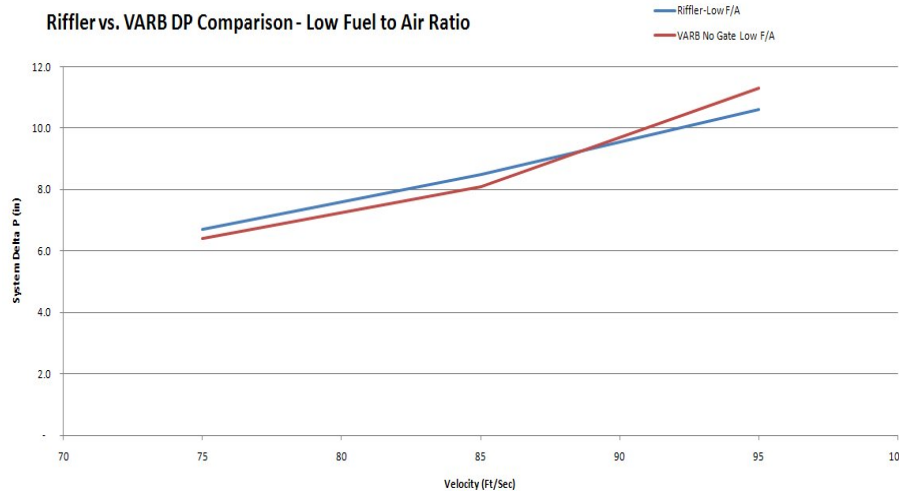

Riffler vs. VARB DP Comparison - High Fuel/Air Ratio

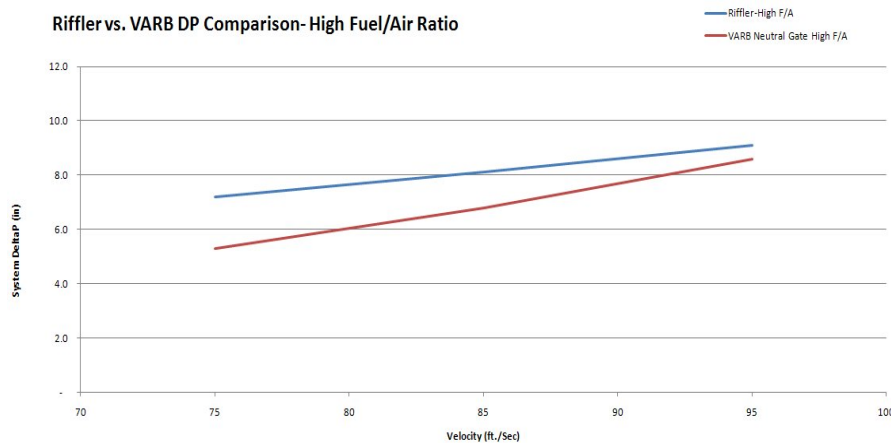

At higher fuel/air ratios consistent with higher unit load, the improvement in DP is even more evident



## Return

- Now back to our discussion on Dynamic Injection Control



## Case Study #3 – Breen Sorbent Injection Biasing

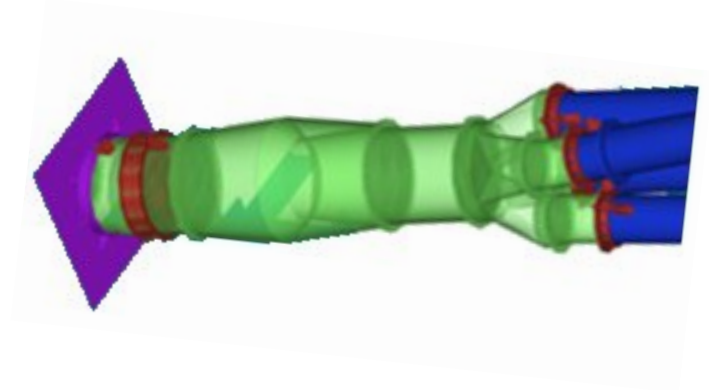
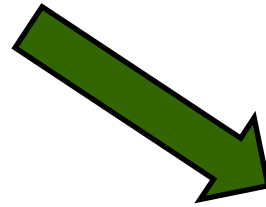

**Step 2 – Replace “spider” with a 4way VARB  
without control Gate**



# Case Study #3 – Breen Sorbent Injection Biasing

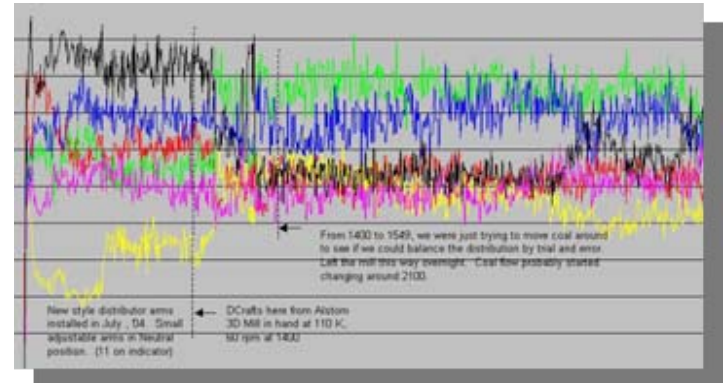

**Step 3 - Replace “site glasses” with on-line flow sensors, this technology also:**

- provides direct feedback on changes in mass flow and velocity
- removes the need for multiple gravimetric feeders
- Provides predictive lance fouling information avoiding injector plugging



## Case Study #3 – Breen Sorbent Injection Biasing

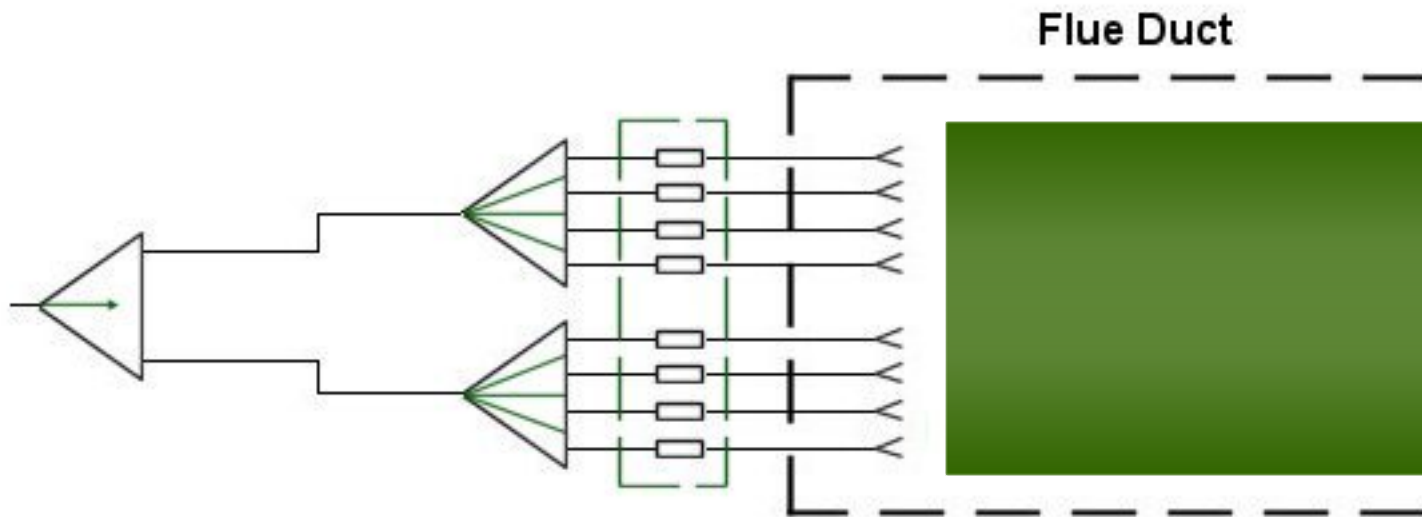

**The resulting system can:**

- **Bias sorbent flow to match measured acid vapor concentration and**
- **Provide real-time line specific flow feedback to reduce maintenance.**



# ***Summary and Conclusion***

---



# Dynamic Measurement and Control

- To meet 0.005 #/mmBTU SO<sub>3</sub> emissions, and still meet existing stack particulate emissions requirements, Sorbent type and injection distribution must be matched to acid levels
- Technology has evolved to allow real time measurement of acid level and location within the ductwork,
- Injection technology has now evolved to allow real time biasing of injection rates to match acid concentration and location



***Thank You!***

---

Questions?